

OSI PRECISION AC WATT OR VAR TRANSDUCER MODELS GW5-/GV5-

ACCURATE TO 0.2% OF READING

DESCRIPTION

The model GW5 Watt transducer provides real power measurements.

The Model GV5 VAR transducer provides reactive power measurements.

Accuracy, for sine-wave applications, is maintained to within $\pm 0.2\%$ of reading. Electrically isolated outputs are proportional to the instantaneous power averaged over several cycles.

Voltages up to 600V and currents up to 20A are directly connected to the transducer, thus eliminating the additional cost of current or voltage transformers. Currents from 20A to 200A are accommodated with external current transformers in either solid or split-core versions.

A wide variety of output types is available to allow interface with any data acquisition system from a simple recorder to computer, SCADA or PLC based systems.

Transducers are housed in a rugged metal can with barrier style terminal strips for I/O connections.

5 YEAR WARRANTY



APPLICATIONS

- Equipment monitoring for process control.
- Energy management / building automation.
- Sub-metering.
- Appliance testing.
- Monitoring of generation / co-generation systems.

FEATURES

- Accurate regardless of variations in voltage, current, power factor, or load.
- Available in 1, 1½, 2, 2½, or 3 element configurations.
- Provides Leading/Lagging VAR indication.
- Accuracy of $\pm 0.2\%$ Rdg. is maintained over a wide temperature range.
- Split-core CTs provide ease of installation.
- C of C with NIST traceability is available..

MODEL SELECTION

SINGLE-PHASE, TWO-WIRE (ONE-ELEMENT) MODELS WITH INTERNAL CURRENT SENSOR



AC INPUTS		F.S. WATTS or VARS	STANDARD OUTPUTS MODEL GW5- OR GV5-									
VOLTS	AMPS		0-±1mAdc*	0-±1mAdc	0-±10Vdc*	0-±10Vdc	4-20mAdc	4-20mA*	4-12-20mA	4-12-20mA*	0-±5Vdc*	0-±5Vdc
0-150	0 - 1	100	103A	103B	103C	103D	103E	103EG	103EM	103EMG	103CX5	103X5
	0 - 2.5	250	106A	106B	106C	106D	106E	106EG	106EM	106EMG	106CX5	106X5
	0 - 5	500	001A	001B	001C	001D	001E	001EG	001EM	001EMG	001CX5	001X5
	0 - 10	1k	010A	010B	010C	010D	010E	010EG	010EM	010EMG	010CX5	010X5
	0 - 20	2k	019A	019B	019C	019D	019E	019EG	019EM	019EMG	019CX5	019X5
0-300	0 - 1	200	104A	104B	104C	104D	104E	104EG	104EM	104EMG	104CX5	104X5
	0 - 2.5	500	107A	107B	107C	107D	107E	107EG	107EM	107EMG	107CX5	107X5
	0 - 5	1k	002A	002B	002C	002D	002E	002EG	002EM	002EMG	002CX5	002X5
	0 - 10	2k	011A	011B	011C	011D	011E	011EG	011EM	011EMG	011CX5	011X5
	0 - 20	4k	020A	020B	020C	020D	020E	020EG	020EM	020EMG	020CX5	020X5
0-600	0 - 1	500	105A	105B	105C	105D	105E	105EG	105EM	105EMG	105CX5	105X5
	0 - 2.5	1k	108A	108B	108C	108D	108E	108EG	108EM	108EMG	108CX5	108X5
	0 - 5	2k	003A	003B	003C	003D	003E	003EG	003EM	003EMG	003CX5	003X5
	0 - 10	4k	012A	012B	012C	012D	012E	012EG	012EM	012EMG	012CX5	012X5
	0 - 20	8k	021A	021B	021C	021D	021E	021EG	021EM	021EMG	021CX5	021X5

**Voltage specifications are line-to-neutral voltage.

*Denotes self-powered unit, limiting input voltage ranges to:

85-135 for 150Vac models

200-280 for 300Vac models

380-550 for 600Vac models

All others require 85-135Vac instrument power, 60Hz.

Optional 50ms output response to 90% - Add suffix "W"

Optional 230Vac instrument power - Add suffix "-22"

For UL Listed precision Watt transducers, see AGW Series.

50 HERTZ MODELS:

Add suffix "-50" to part number.

ORDERING INFORMATION

Example: Self-Powered, Three-Phase, Four-Wire, 120V, 5A Input with 0-±5Vdc Output, Proportional to 0-±1500Watts.

GW5-007CX5

ORDERING INFORMATION

Example: Self-Powered, Three-Phase, Four-Wire, 120V, 5A Input with 0-±1mAdc Output, Proportional to 0-±1500VAR.

GV5-007A

OHIO SEMITRONICS, INC. 4242 REYNOLDS DRIVE * HILLIARD, OHIO * 43026-1264
 PHONE: (614) 777-1005 * FAX: (614) 777-4511
 WWW.OHIOSEMITRONICS.COM * 1-800-537-6732

OSI PRECISION AC WATT OR VAR TRANSDUCER MODELS GW5-/GV5-

SINGLE-PHASE, TWO-WIRE (ONE-ELEMENT) MODELS SUPPLIED WITH EXTERNAL SENSOR



AC INPUTS		F.S. WATTS or VARS	STANDARD OUTPUTS MODEL GW5- OR GV5-									
VOLTS	AMPS		0-±1mAdc*	0-±1mAdc	0-±10V*	0-±10Vdc	4-20mAdc	4-20mA*	4-12-20mA	4-12-20mA*	0-±5Vdc*	0-±5Vdc
0-150	0 - 100	10k	058AS	058BS	058CS	058DS	058ES	058EGS	058EMS	058EMGS	058CX5S	058X5S
	0 - 200	20k	067AS	067BS	067CS	067DS	067ES	067EGS	067EMS	067EMGS	067CX5S	067X5S
0-300	0 - 100	20k	059AS	059BS	059CS	059DS	059ES	059EGS	059EMS	059EMGS	059CX5S	059X5S
	0 - 200	40k	068AS	068BS	068CS	068DS	068ES	068EGS	068EMS	068EMGS	068CX5S	068X5S
0-600	0 - 100	40k	060AS	060BS	060CS	060DS	060ES	060EGS	060EMS	060EMGS	060CX5S	060X5S
	0 - 200	80k	069AS	069BS	069CS	069DS	069ES	069EGS	069EMS	069EMGS	069CX5S	069X5S

NOTE: Split-core Current Transformer is supplied as part of the model. For solid-core CTs, remove the "S" from the model number. Refer also to notes below table on first page.

THREE-PHASE, THREE-WIRE (TWO-ELEMENT) MODELS WITH INTERNAL CURRENT SENSORS



AC INPUTS		F.S. WATTS or VARS	STANDARD OUTPUTS MODEL GW5- OR GV5-									
VOLTS	AMPS		0-±1mAdc*	0-±1mAdc	0-±10Vdc*	0-±10Vdc	4-20mAdc	4-20mA*	4-12-20mA	4-12-20mA*	0-±5Vdc*	0-±5Vdc
0-150	0 - 1	200	120A	120B	120C	120D	120E	120EG	120EM	120EMG	120CX5	120X5
	0 - 2.5	500	129A	129B	129C	129D	129E	129EG	129EM	129EMG	129CX5	129X5
	0 - 5	1k	004A	004B	004C	004D	004E	004EG	004EM	004EMG	004CX5	004X5
	0 - 5	1k	4.5A	4.5B	4.5C	4.5D	4.5E	4.5EG	4.5EM	4.5EMG	4.5CX5	4.5X5
	0 - 10	2k	013A	013B	013C	013D	013E	013EG	013EM	013EMG	013CX5	013X5
0 - 20	4k	022A	022B	022C	022D	022E	022EG	022EM	022EMG	022CX5	022X5	
0-300	0 - 1	400	121A	121B	121C	121D	121E	121EG	121EM	121EMG	121CX5	121X5
	0 - 2.5	1k	130A	130B	130C	130D	130E	130EG	130EM	130EMG	130CX5	130X5
	0 - 5	2k	005A	005B	005C	005D	005E	005EG	005EM	005EMG	005CX5	005X5
	0 - 10	4k	014A	014B	014C	014D	014E	014EG	014EM	014EMG	014CX5	014X5
	0 - 20	8k	023A	023B	023C	023D	023E	023EG	023EM	023EMG	023CX5	023X5
0-600	0 - 1	800	122A	122B	122C	122D	122E	122EG	122EM	122EMG	122CX5	122X5
	0 - 2.5	2k	131A	131B	131C	131D	131E	131EG	131EM	131EMG	131CX5	131X5
	0 - 5	4k	006A	006B	006C	006D	006E	006EG	006EM	006EMG	006CX5	006X5
	0 - 10	8k	015A	015B	015C	015D	015E	015EG	015EM	015EMG	015CX5	015X5
	0 - 20	16k	024A	024B	024C	024D	024E	024EG	024EM	024EMG	024CX5	024X5

NOTE: Model number 4.5 denotes 1/2-element unit. Refer also to notes below table on first page.

THREE-PHASE, THREE-WIRE (TWO-ELEMENT) MODELS SUPPLIED WITH EXTERNAL SENSORS



AC INPUTS		F.S. WATTS or VARS	STANDARD DC OUTPUTS MODEL GW5- OR GV5-									
VOLTS	AMPS		0-±1mAdc*	0-±1mAdc	0-±10Vdc*	0-±10Vdc	4-20mAdc	4-20mA*	4-12-20mA	4-12-20mA*	0-±5Vdc*	0-±5Vdc
0-150	0 - 100	20k	061AS	061BS	061CS	061SD	061ES	061EGS	061EMS	061EMGS	061CX5S	061X5S
	0 - 200	40k	070AS	070BS	070CS	070SD	070ES	070EGS	070EMS	070EMGS	070CX5S	070X5S
0-300	0 - 100	40k	062AS	062BS	062CS	062SD	062ES	062EGS	062EMS	062EMGS	062CX5S	062X5S
	0 - 200	80k	071AS	071BS	071CS	071SD	071ES	071EGS	071EMS	071EMGS	071CX5S	071X5S
0-600	0 - 100	80k	063AS	063BS	063CS	063SD	063ES	063EGS	063EMS	063EMGS	063CX5S	063X5S
	0 - 200	160k	072AS	072BS	072CS	072SD	072ES	072EGS	072EMS	072EMGS	072CX5S	072X5S

NOTE: Split-core Current Transformers are supplied as part of the model. For solid-core CTs, remove the "S" from the model number. Refer also to notes below table on first page.

OSI PRECISION AC WATT OR VAR TRANSDUCER MODELS GW5-/GV5-

THREE-PHASE, FOUR-WIRE (THREE-ELEMENT) MODELS WITH INTERNAL CURRENT SENSORS



AC INPUTS		F.S. WATTS or VARS	STANDARD OUTPUTS MODEL GW5- OR GV5-									
VOLTS	AMPS		0-±1mAdc*	0-±1mAdc	0-±10Vdc*	0-±10Vdc	4-20mAdc	4-20mA*	4-12-20mA	4-12-20mA*	0-±5Vdc*	0-±5Vdc
0-150 L-N**	0 - 1	300	125A	125B	125C	125D	125E	125EG	125EM	125EMG	125CX5	125X5
	0 - 2.5	750	132A	132B	132C	132D	132E	132EG	132EM	132EMG	132CX5	132X5
	0 - 5	1.5k	007A	007B	007C	007D	007E	007EG	007EM	007EMG	007CX5	007X5
	0 - 5	1.5k	7.5A	7.5B	7.5C	7.5D	7.5E	7.5EG	7.5EM	7.5EMG	7.5CX5	7.5X5
	0 - 10	3k	016A	016B	016C	016D	016E	016EG	016EM	016EMG	016CX5	016X5
	0 - 20	6k	025A	025B	025C	025D	025E	025EG	025EM	025EMG	025CX5	025X5
0-300 L-N**	0 - 1	600	126A	126B	126C	126D	126E	126EG	126EM	126EMG	126CX5	126X5
	0 - 2.5	1.5k	133A	133B	133C	133D	133E	133EG	133EM	133EMG	133CX5	133X5
	0 - 5	3k	008A	008B	008C	008D	008E	008EG	008EM	008EMG	008CX5	008X5
	0 - 5	3k	8.5A	8.5B	8.5C	8.5D	8.5E	8.5EG	8.5EM	8.5EMG	8.5CX5	8.5X5
	0 - 10	6k	017A	017B	017C	017D	017E	017EG	017EM	017EMG	017CX5	017X5
	0 - 20	12k	026A	026B	026C	026D	026E	026EG	026EM	026EMG	026CX5	026X5

NOTE: Model numbers 7.5 and 8.5 denote 2½-element units. Refer also to notes below table on first page.

THREE-PHASE, FOUR-WIRE (THREE-ELEMENT) MODELS SUPPLIED WITH EXTERNAL SENSORS



AC INPUTS		F.S. WATTS or VARS	STANDARD DC OUTPUTS MODEL GW5- OR GV5-									
VOLTS	AMPS		0-±1mAdc*	0-±1mAdc	0-±10Vdc*	0-±10Vdc	4-20mAdc	4-20mA*	4-12-20mA	4-12-20mA*	0-±5Vdc*	0-±5Vdc
0-150 L-N**	0 - 100	30k	064AS	064BS	064CS	064DS	064ES	064EGS	064EMS	064EMGS	064CX5S	064X5S
	0 - 200	60k	073AS	073BS	073CS	073DS	073ES	073EGS	073EMS	073EMGS	073CX5S	073X5S
0-300 L-N**	0 - 100	60k	065AS	065BS	065CS	065DS	065ES	065EGS	065EMS	065EMGS	065CX5S	065X5S
	0 - 200	120k	074AS	074BS	074CS	074DS	074ES	074EGS	074EMS	074EMGS	074CX5S	074X5S

NOTE: Split-core Current Transformers are supplied as part of the model. For solid-core CTs, remove the "S" from the model number. Refer also to notes below table on first page.

SPECIFICATIONS

INPUT

Voltage See Tables
 Current See Tables
 Frequency Range
 GW5 standard 58-62Hz
 with "-50" option 48-52Hz
 GV5 standard 60Hz
 with "-50" option 50Hz
 Power Factor Any
 Burden
 Voltage ≤0.1VA/element
 Current ≤0.28VA/element
 Overload
 Voltage ..continuous...0-150Vac Range 175Vac
 0-300Vac Range 350Vac
 0-600Vac Range 600Vac
 Current ..continuous...0-1, 2.5, 5, 10Aac Ranges .. 2 X F.S.
 0-20Aac Range 20A
 transient0-1, 2.5Aac Ranges... 20A...10s/hr
 0-5,10, 20A Ranges... 50A...10s/hr
 0-1, 2.5Aac Ranges... 100A...1s/hr
 0-5,10, 20A Ranges... 250A...1s/hr

INSTRUMENT POWER

"B", "D", "E", "EM", "X5" models 85-135Vac, 60Hz, 7VA
 "-22" option 230Vac, 50/60Hz, ±15%
 "A", "C", "CX5", "EG" or "EMG" models Not required

OUTPUT

GV5 + = Lagging/ - = Leading
 Loading
 "A" & "B" models (0-1mA output) 0-10kΩ
 "C" & "D" models (0-10Vdc output) 2kΩ min.
 "E", "EG", "EM", "EMG" models (4-20mAdc output) 0-500Ω
 "CX5" & "X5" models ... (0-5Vdc output) 2kΩ min.
 Response standard (to 99%) ≤400ms
 "W" option (to 90%) ≤50ms
 Field Adjustable Cal. ±2%

DIELECTRIC TEST

Input/Output/Case 1800Vac, 60Hz
 Surge Withstands IEEE SWC test

TEMPERATURE and HUMIDITY

Temperature.... Operating Range -20°C to 65°C
 Effect ±0.005%/°C
 Storage Range -40°C to 70°C
 Humidity Operating Range 0-95% non-condensing

ACCURACY (setpoint, linearity and repeatability)

Internal sensor models - applies to 0-100% of rated input
 External sensor models - applies to 5-100% of rated input
 GW5 ±0.2% Rdg./PF, ±0.04% F.S.
 GV5 ±0.2% Rdg./sinθ, ±0.04% F.S.
 Output Ripple <0.5% F.S.

OHIO SEMITRONICS, INC.

4242 REYNOLDS DRIVE * HILLIARD, OHIO * 43026-1264
 PHONE: (614) 777-1005 * FAX: (614) 777-4511
 WWW.OHIOSEMITRONICS.COM * 1-800-537-6732

SINGLE-PHASE CONNECTIONS

(1 ELEMENT)

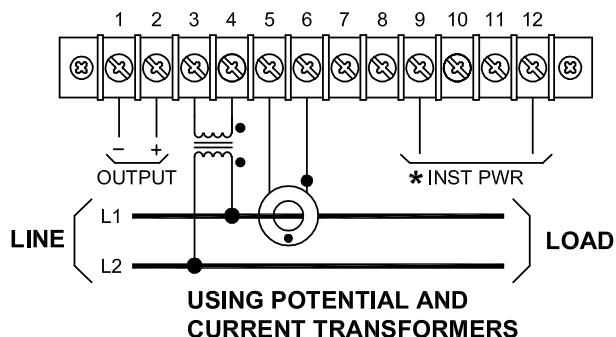
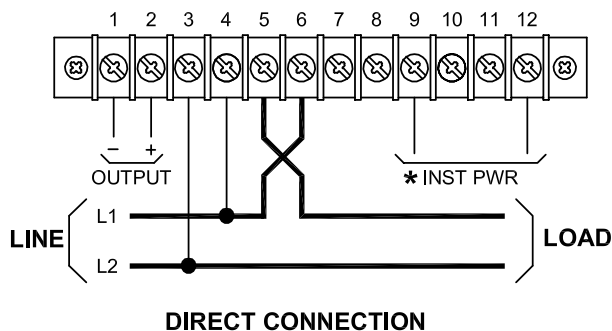

THREE-PHASE, THREE-WIRE CONNECTIONS

(1-1/2 ELEMENT)

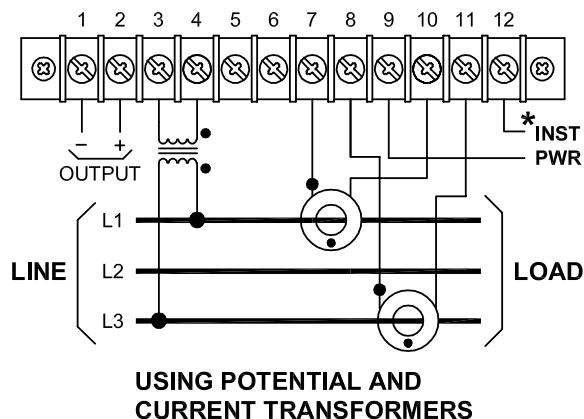
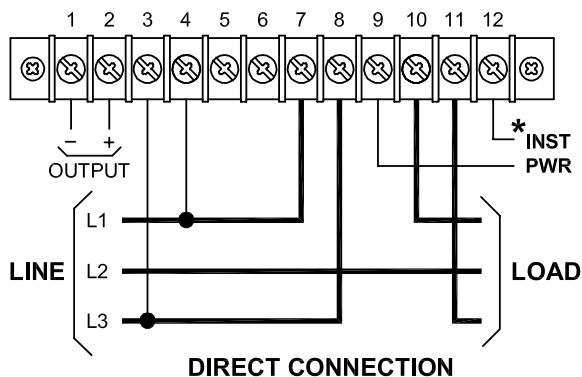

THREE-PHASE, THREE-WIRE CONNECTIONS

(2 ELEMENT)

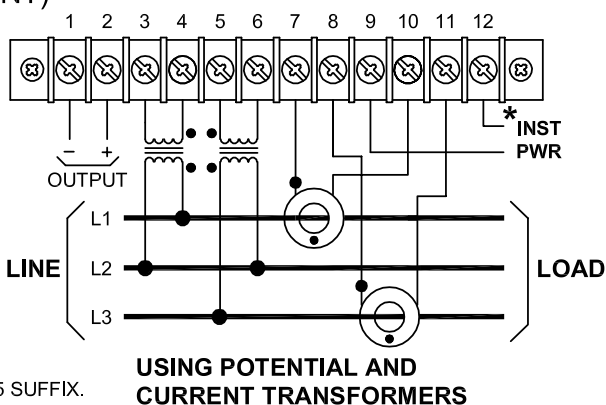
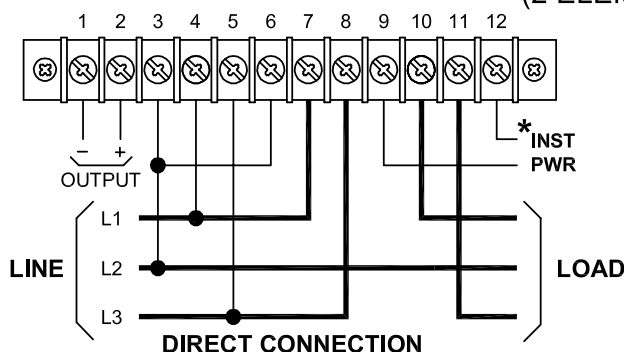

- * 115Vac ON MODELS WITH B, D, E, EM OR X5 SUFFIX.
- * 230Vac ON MODELS WITH -22 SUFFIX.
- * NOT REQUIRED ON MODELS WITH A, C, CX5, EG OR EMG SUFFIX.

Dwg# 0902-00873-B Rev A

THREE-PHASE, FOUR-WIRE CONNECTIONS

(2-1/2 ELEMENT)

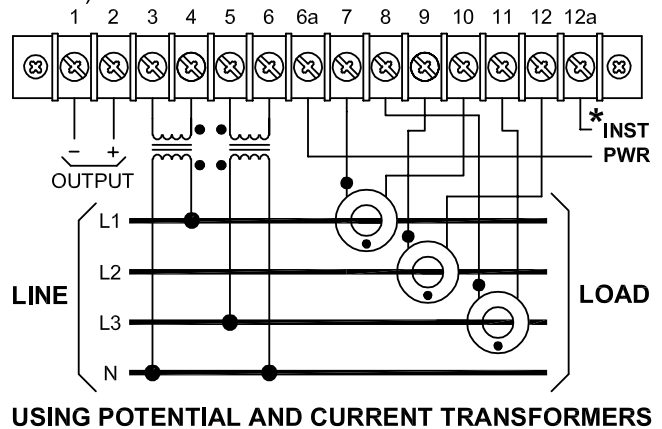
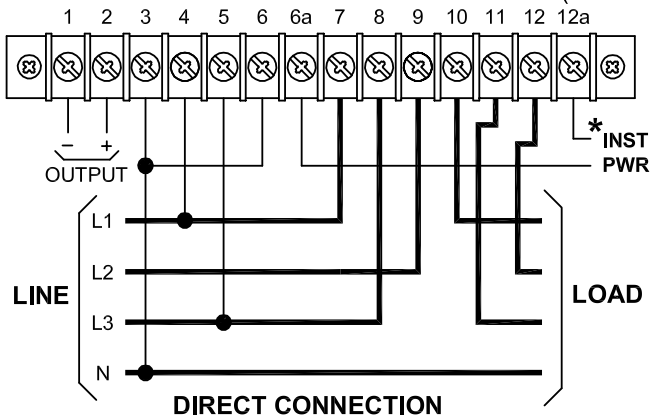

THREE-PHASE, FOUR-WIRE CONNECTIONS

(3 ELEMENT)

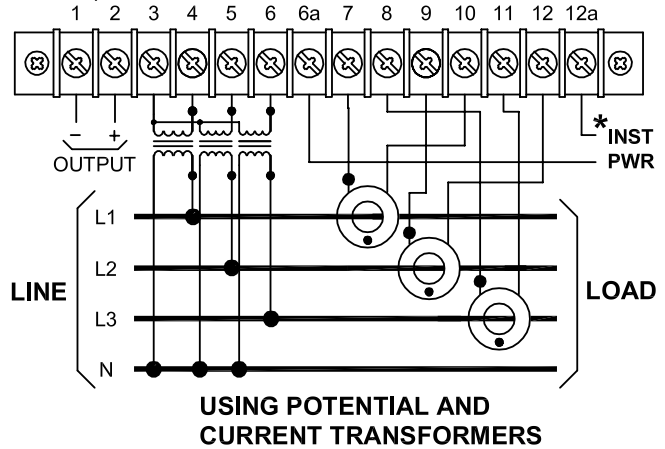
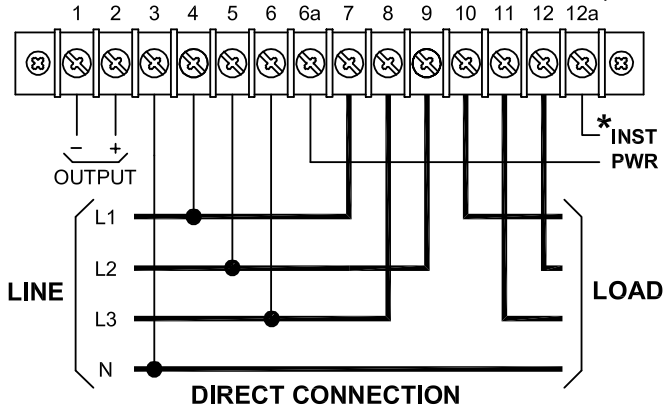

- * 115Vac ON MODELS WITH B, D, E, EM OR X5 SUFFIX.
- * 230Vac ON MODELS WITH -22 SUFFIX.
- * NOT REQUIRED ON MODELS WITH A, C, CX5, EG OR EMG SUFFIX.

CASE DIMENSIONS

MODELS WITH 1mA, 5V OR 10V OUTPUTS

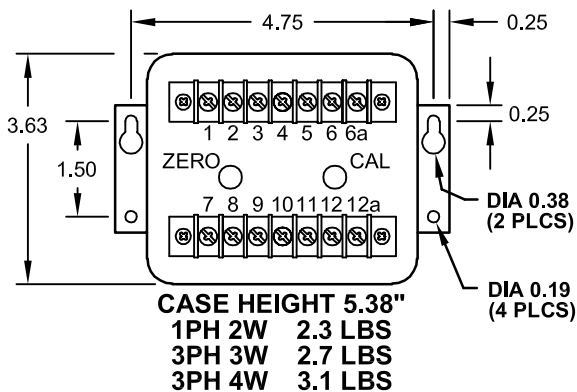

MODELS WITH 4-20mA OUTPUTS

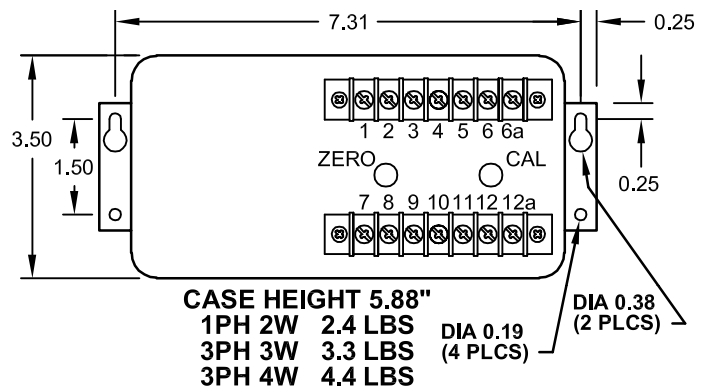

All dimensions in inches. Tolerance - 0.00±0.03 (unless otherwise specified)

Dwg# 0902-00873-B Rev A

SPLIT-CORE SENSOR

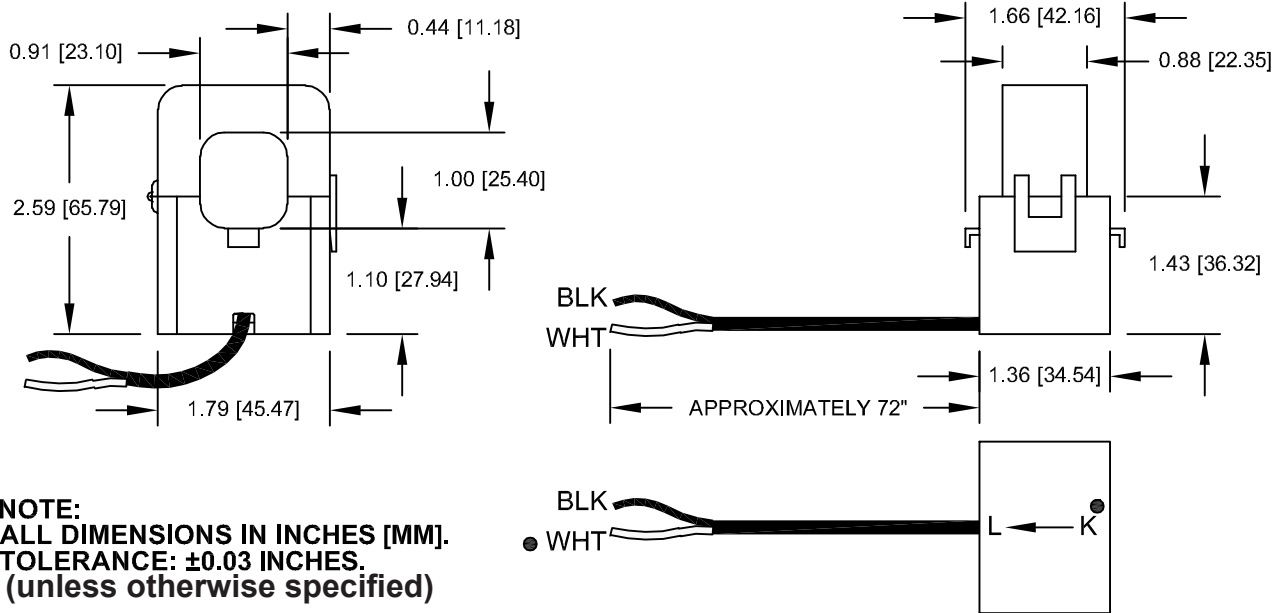

NOTE:
ALL DIMENSIONS IN INCHES [MM].
TOLERANCE: ±0.03 INCHES.
(unless otherwise specified)

CURRENT DIRECTION ARROW
BOTTOM VIEW

Dwg# 0902-01003-B Rev A

SOLID-CORE SENSOR

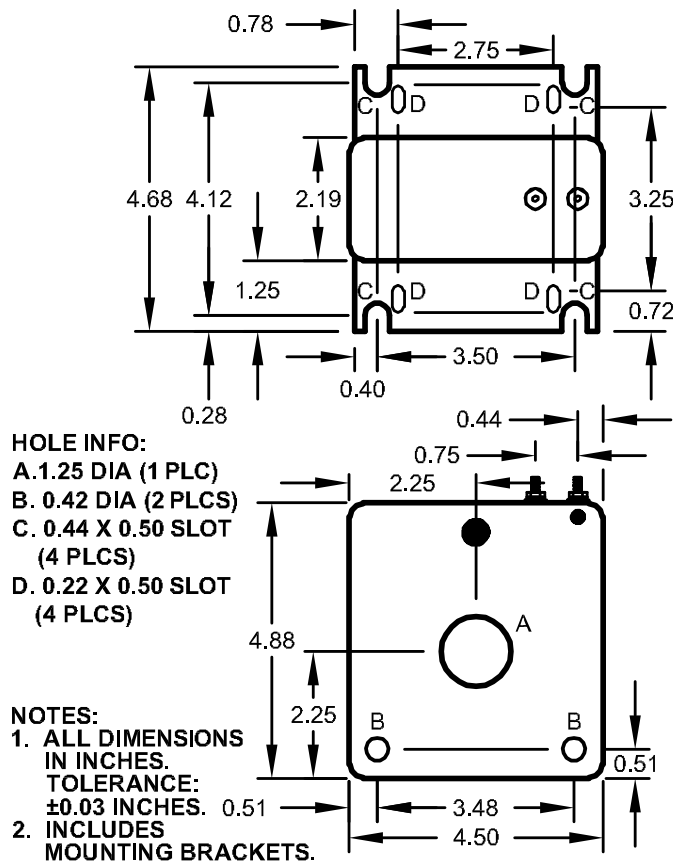

Dwg# 0902-00920-B Rev --